



CF2-ES18



CF2-ES27

### MODELS

- CF2-ES18
- CF2-ES27

### FEATURES

- Digital temperature control, 50-200° C.
- Long-life SUS 316 Sheath heater.
- Stainless steel fryer tank.
- Stainless steel front, sides.
- Hi-limit shut-off.
- Heater swing-up type for easy cleaning
- Heater swing-up ON-OFF switch for safety.

### DESCRIPTION



Digital control enables increments of 1°C temperature setting. Long-life SUS 316 Sheath heater is equipped. Front and side boards and fryer tank are stainless steel. Hi-limit shut-off device prevents from abnormal rise of oil temperature. Heater swing up mechanism is useful for easy cleaning.

### ACCESSORIES

- Oil strainer set
- Tank cover
- Wasted oil can
- Filtration basket

**COMET KATO MFG.CO.,LTD.**

[www.cometkato.co.jp](http://www.cometkato.co.jp)

65, Iku, Kabutoshinden, Sobuecho, Inazawa-shi, Aichipref, Japan 495-8517

Telephone 81-587-97-8441 / Fax 81-587-97-8448 / E-mail [sales@cometkato.co.jp](mailto:sales@cometkato.co.jp)

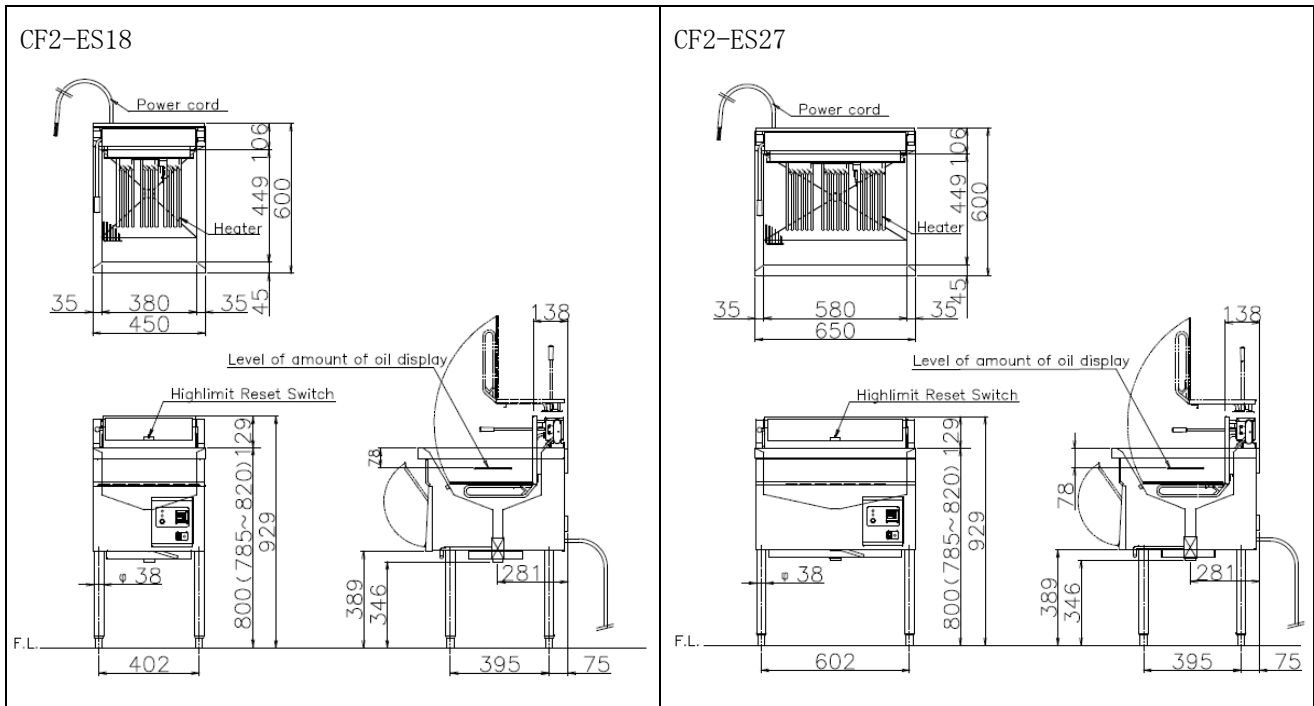

### SPECIFICATION

Models	Dimensions (mm)			Electric Connection (3ph 4wire + ground)		Weight (kg)	Oil Capacity
	Width	Depth	Height	380V	415V		
CF2-ES18	450	600	800	6.9kW	6.0kW	39	18L
CF2-ES27	650	600	800	10.5kW	9.3kW	52	27L

IMPORTANT: SPECIFY VOLTAGE AT YOUR ORDER.

The contents of this specification are subject to change without notice.

**COMET KATO MFG.CO.,LTD.** [www.cometkato.co.jp](http://www.cometkato.co.jp)

65, Iku, Kabutoshinden, Sobuecho, Inazawa-shi, Aichipref, Japan 495-8517

Telephone 81-587-97-8441 / Fax 81-587-97-8448 / E-mail [sales@cometkato.co.jp](mailto:sales@cometkato.co.jp)